



## ENGINE

Model	: ISUZU-4JJ1X
Type	: Water cooled, 4 cycle, 4 cylinders, line type direct injection, turbocharger, electronic diesel engine
Power	: 105 HP (78,5 kW) @2000 rpm / SAE J1995 (Gross) : 102 HP (76,4 kW) @2000 rpm / SAE J1349 (Net)
Max. Torque	: 375 Nm @1800 rpm (Gross) : 367 Nm @1800 rpm (Net)
Displacement	: 2999 cc
Bore and Stroke	: 95,4 mm x 104,9 mm
Emission Class	: EU Stage-V

## UNDERCARRIAGE

Shoe	: Triple grouser 500 mm
No. Of Shoes	: 2 x 46
No. Of Lower Rollers	: 2 x 7
No. Of Upper Rollers	: 2 x 2
Track Tensioning	: Hydraulic Spring Tensioning

## CAB

- Improved operator's all round visibility
- Increased cabin internal space
- Use of six viscomount cabin mountings that dampen the vibrations
- High capacity A/C
- High resolution, led backlight, color LCD display
- Opera Control System
- Cooled storage room
- Glass holder, book and object storage pockets
- Pool type floor mat
- Improved operator's comfort through versatile adjustable seat
- Ergonomically redesigned cabin through relocated switch board, and re-styled travel pedals and joysticks.

## TRAVEL AND BRAKERS

Travel	: Fully hydrostatic
Travel Motors	: Axial piston type
Reduction	: 2 stage planetary gear
Travel Speed	
High Speed	: 5,7 km/h
Low Speed	: 3,4 km/h
Max. Drawbar Pull	: 11.230 kgf
Gradeability	: 35° (%70)
Parking Brake	: Hydraulic disc type, automatic warnings
Ground Pressure (500mm Shoe):	0,48 kgf/cm <sup>2</sup>

## LUBRICATION

Centralized lubrication system is provided for lubrication all difficult-to-reach parts on the components, such as boom and arm

## HYDRAULIC SYSTEM

Main Pump	
Type	: Double variable displacement axial piston pumps
Max. Flow	: 2 x 129 L/min
Pilot Pump	: 20 L/min
Relief Valves	
Cylinders	: 350 kgf/cm <sup>2</sup>
Power Boost	: 372 kgf/cm <sup>2</sup>
Travel	: 350 kgf/cm <sup>2</sup>
Swing	: 300 kgf/cm <sup>2</sup>
Pilot	: 40 kgf/cm <sup>2</sup>
Cylinders	
Boom	: 2 x ø105 x ø75 x 1080 mm
Arm	: 1 x ø115 x ø80 x 1220 mm
Bucket	: 1 x ø95 x ø70 x 910 mm

## OPERA CONTROL SYSTEM

- Easy-to-use control panel and menus
- Overheat prevention and protection system without interrupting the work
- Automatic electric power-off
- Maximum efficiency by selection of power and work modes
- Error mode registry and warning system
- Improved fuel economy and productivity
- Automatic idling Selection of multi-language on control panel
- Rear-view, arm-view camera (Optional)
- Possibility to register 27 different operating hours
- Anti-theft system with personal code
- Real time monitoring of operational parameters such as pressure, temperature, engine load

## SWING SYSTEM

Swing Motor	: Axial piston type integrated with shock absorber valves
Reduction	: 2 stage planetary gear box.
Swing Brakes	: Hydraulic disc type, automatic warnings
Swing Speed	: 11,3 rpm

## CAPACITY

Fuel Tank	: 235 L	Engine Oil	: 16 L
Hydraulic Tank	: 115 L	Radiator	: 20 L
Hydraulic System	: 205 L	Urea	: 33 L

## ELECTRICAL SYSTEM

Voltage	: 24V
Battery	: 2 x 12 V x 100 Ah
Alternator	: 24V / 50 A
Starting Motor	: 24V / 4 kW

## OPERATING WEIGHT

Standard machine operating weight	: 16.700 kg
-----------------------------------	-------------

Operational weight, complying with the ISO 6016 standards, includes full fuel tank, hydraulic system and other liquids, 75 kg operator weight and standard equipped machine weight. Optional equipments are not included.

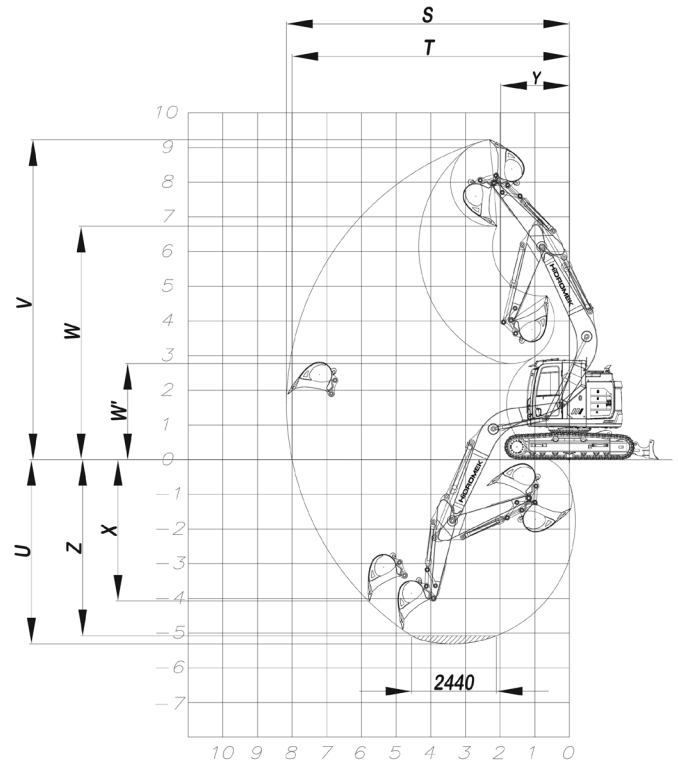
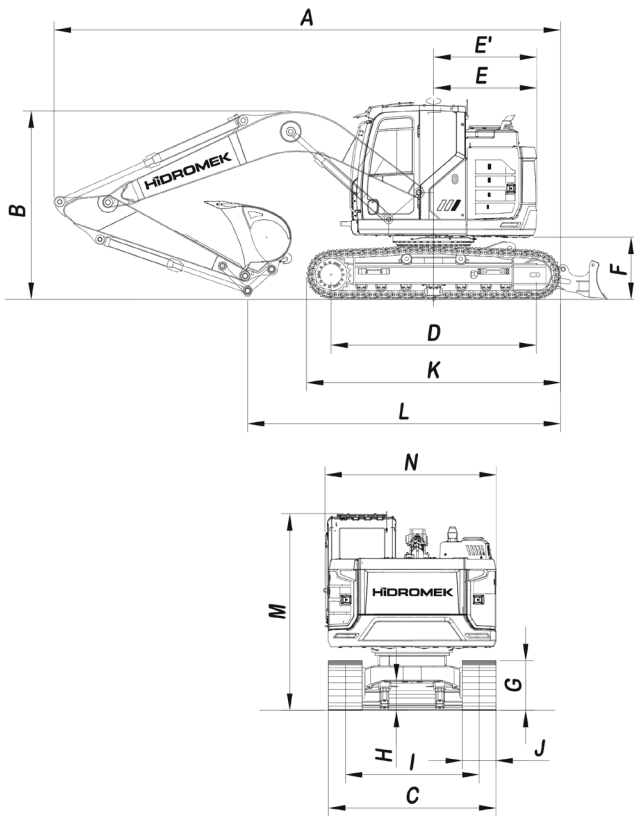

## GENERALE DIMENSIONS

Boom dimension	4600 mm		
Arm dimension	*2300 mm	2600 mm	2900 mm
A - Overall length	7520 mm	7450 mm	7440 mm
B - Overall height (to top of boom)	3290 mm	2950 mm	3010 mm
C - Overall width (of lower structure)	2510 mm		
D - Idler distance	3035 mm		
E - Tall swing radius	1500 mm		
E' - Tall swing distance	1520 mm		
F - Upperstructure ground clearance	940 mm		
G - Crawler height	830 mm		
H - Min. Ground clearance	430 mm		
I - Track gauge	1990 mm		
J - Shoe width	500 mm		
K - Overall length of crawler	3780 mm		
L - Length over ground	4580 mm	4440 mm	4190 mm
M - Overall height (to top of cab)	2960 mm		
N - Upperstructure width	2500 mm		

\* Standard

## WORKING DIMENSIONS

Boom dimension	4600 mm		
Arm dimension	*2300 mm	2600 mm	2900 mm
S - Max.digging reach	8200 mm	8510 mm	8790 mm
T - Max.digging reach at ground level	8040 mm	8350 mm	8640 mm
U - Max.digging depth	5360 mm	5660 mm	5960 mm
V - Max.digging height	9260 mm	9540 mm	9790 mm
W - Max.dumping height	6680 mm	6960 mm	7200 mm
W' - Min.dumping height	2710 mm	2440 mm	2130 mm
X - Max.vertical digging depth	4830 mm	5180 mm	5470 mm
Y - Min.swing radius	1960 mm	2100 mm	2140 mm
Z - Max. digging depth(2440mm level)	5130 mm	5450 mm	5770 mm

## DIGGING PERFORMANCE

Bucket Capacity (SAE)	*0,6 m <sup>3</sup>		
Bucket Digging Force (Power Boost) ISO	9500 (10000) kgf		
Arm Crowd Force (Power Boost) ISO	6900 (7300) kgf	6300 (6700) kgf	5800 (6100) kgf

## HIDROMEK®

### FACTORY - HEAD OFFICE

Ahi Evran OSB Mahallesi Osmanlı Caddesi No:1 06935 Sincan / ANKARA / TURKEY  
Tel: (+90) 312 267 12 60 Fax: (+90) 312 267 12 39  
www.hidromek.com

**Notice:**  
Hidromek has the right to modify the specifications and design of the model indicated on this brochure without prior notice.