



NEW!

ENGINE

Model	: ISUZU-6UZ1X
Type	: Water-cooled, 4 cycle, 6 cylinders, line type, direct injection, turbocharger, intercooler, diesel engine
Power	: 362 HP (270 kW) @2000 rpm / SAE J1995 (Gross)
Max. Torque	: 1650 Nm @1300 rpm (Gross)
Displacement	: 9839 cc
Bore and Stroke	: \varnothing 120 mm x 145 mm
Emission Class	: Stage V-EU

UNDERCARRIAGE

X Type Lower Frame Construction Pentagon Box Type Chassis	
Shoe	: 3 grouser
No. Of Shoes	: 2 x 50
No. Of Lower Rollers	: 2 x 9
No. Of Upper Rollers	: 2 x 2
Full Trackguard	: Complete
Track Tensioning	: Hydraulic Spring Tensioning

CAB

<ul style="list-style-type: none"> • Wide cab and easy entrance • Use of six viscomount cabin mountings that dampen the vibrations • Cooled storage room • Colourful, Easy to read TFT indicant monitor • Glass holder, book and object storage pockets • Full automatic digitally air-conditioner • Overclass standards on the visibility • Pool type flor mat • Improved operator's comfort through versatile adjustable seat • Ergonomically redesigned cabin through relocated switch board, and re-styled travel pedals and joysticks. • USB connected MP3 player • Easy to open the front sliding glass • Front and rear sun visor • Large storage areas • Improved seat to back angle • The height adjustable seat armrests • Opera Control System
--

TRAVEL AND BRAKERS

Travel	: Fully hydrostatic
Travel Motors	: Axial piston type
Reduction	: 3 stage planetary gear
Travel Speed	
High Speed	: 4,60 km/h
Low Speed	: 2,80 km/h
Max. Drawbar Pull	: 35,880 kgf
Gradeability	: 35° (%70)
Parking Brake	: Hydraulic multi disc type, integrated transmission
Ground Pressure (600mm Shoe)	: 0,91 kgf/cm ²

HYDRAULIC SYSTEM

Main Pump	
Type	: Double variable displacement axial piston pumps
Max. Flow	: 2 x 376 L/min
Pilot Pump	: 29 L/min
Relief Valves	
Attachment	: 330 kgf/cm ²
Power Boost	: 355 kgf/cm ²
Travel	: 330 kgf/cm ²
Swing	: 330 kgf/cm ²
Pilot	: 40 kgf/cm ²
Cylinders	
Main Boom	: 2 x \varnothing 170 x \varnothing 115 x 1.650 mm
Stick Cylinder	: 1 x \varnothing 190 x \varnothing 130 x 1.870 mm
Bucket Cylinder	: 1 x \varnothing 170 x \varnothing 120 x 1.335 mm

OPERA CONTROL SYSTEM

<ul style="list-style-type: none"> • Automatic idling Selection of multi-language on control panel • Improved fuel economy and productivity • Automatical electric power-off • Maximum efficiency by selection of power and work modes • Error mode registry and warning system • Hidromek Smartlink (Optional) • Automatic preheating • Automatical powerboost 	<ul style="list-style-type: none"> • Overheat prevention and protection system without interrupting the work • Easy-to-use control panel and menus • Rear-view, arm-view camera • Possibility to register 27 different operating hours • Anti-theft system with personal code • Real time monitoring of operational parameters such as pressure, temperature, engine load
---	---

SWING SYSTEM

Swing Motor	: Axial piston type integrated with shock absorber valves
Reduction	: 2 stage planetary gear box.
Swing Brakes	: Hydraulic multi disc type, automatic warnings
Swing Speed	: 8,10 rpm

CAPACITY

Fuel Tank	: 655 L	Engine Oil	: 41 L
Hydraulic Tank	: 370 L	Engine Cooling System	: 65 L
Hydraulic System	: 615 L	Urea Tank	: 33 L

ELECTRICAL SYSTEM

Voltage	: 24 V
Battery	: 2 x 12 V x 165 Ah
Alternator	: 24 V / 50 A
Starting Motor	: 24 V / 5,5 kw

LUBRICATION

Centralized lubrication system is provided for lubrication all difficult-to-reach parts on the components, such as boom and arm

OPERATING WEIGHT

Standard machine operating weight	: 52.000 kg
-----------------------------------	-------------

Operational weight, complying with the ISO 6016 standards, includes full fuel tank, hydraulic system and other liquids, 75kg operator weight and standard equipped machine weight. Optional equipments are not included.

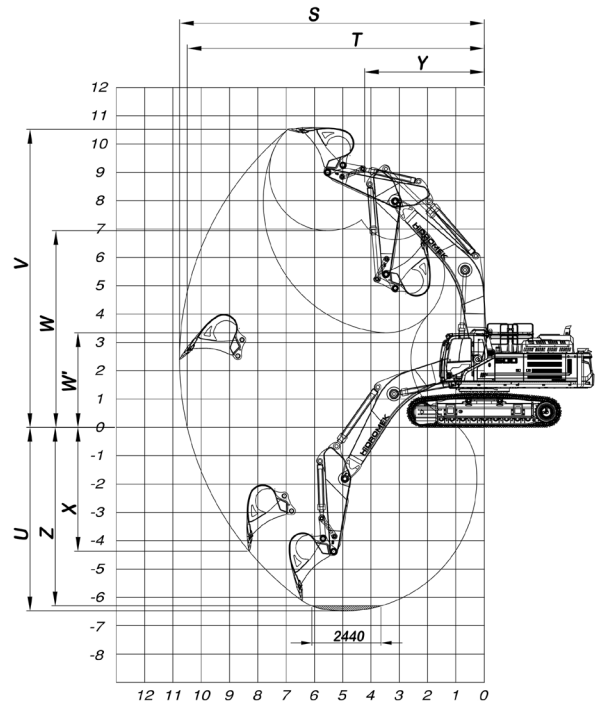
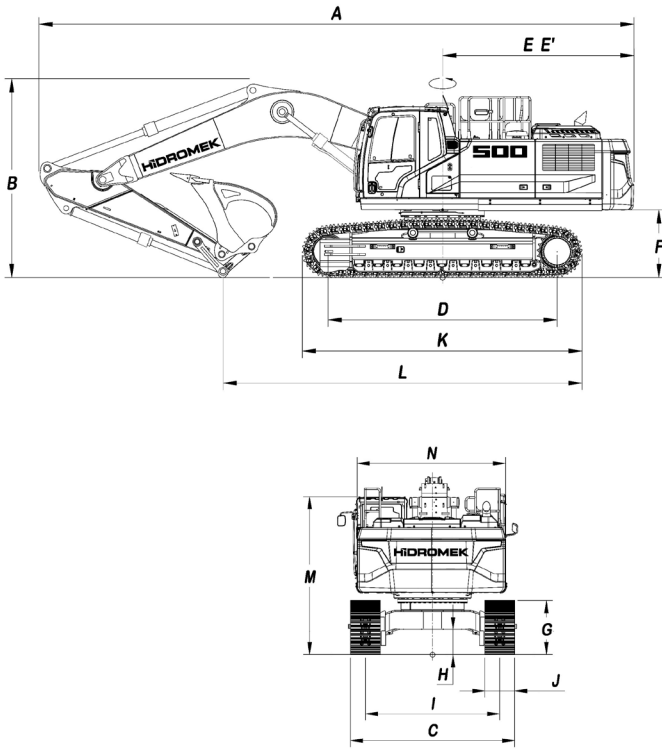

GENERAL DIMENSIONS

Boom Dimension	*6.300 mm		6.900 mm	
Arm Dimension	*2.600 mm	2.900 mm	2.900 mm	3.300 mm
A - Overall Length	11.840 mm	11.850 mm	12.450 mm	12.440 mm
B - Overall Height (to top of boom)	3.860 mm	3.990 mm	3.950 mm	4.160 mm
C - Overall Width	3.500 mm			
D - Idler Distance	4.400 mm			
E - Counterweight Distance	3.985 mm			
E' - Turning Radius	4.005 mm			
F - Upper Structure Ground Clearance	1.385 mm			
G - Crawler Height	1.230 mm			
H - Minimum Ground Clearance	600 mm			
I - Track Gauge	2.900 mm			
J - Shoe Width	600 mm			
K - Overall Length of Crawler	5.500 mm			
L - Length Over Ground	6.910 mm	6.740 mm	7.500 mm	7.310 mm
M - Overall Height (to Top of Cab)	3.360 mm			
N - Upper Structure Width	2.990 mm			

* Standard

WORKING DIMENSIONS

Boom Dimension	6.300 mm		6.900 mm	
Arm Dimension	*2.600 mm	2.900 mm	2.900 mm	3.300 mm
S - Maximum Digging Reach	10.770 mm	11.040 mm	11.680 mm	12.040 mm
T - Maximum Digging Reach at Ground Level	10.490 mm	10.770 mm	11.430 mm	11.800 mm
U - Maximum Digging Depth	6.480 mm	6.780 mm	7.180 mm	7.580 mm
V - Maximum Digging Height	10.510 mm	10.630 mm	11.340 mm	11.530 mm
W - Maximum Dumping Clearance	6.940 mm	7.060 mm	7.710 mm	7.880 mm
W' - Minimum Dumping Clearance	3.330 mm	3.040 mm	3.590 mm	3.190 mm
X - Maximum Vertical Digging Depth	4.470 mm	4.740 mm	5.280 mm	5.740 mm
Y - Minimum Swing Radius	4.320 mm	4.380 mm	4.660 mm	4.750 mm
Z - Maximum Digging Depth (2440 mm level)	6.300 mm	6.610 mm	7.020 mm	7.430 mm

DIGGING PERFORMANCE

Standard Bucket Capacity	3,2 m ³ (SAE)
Bucket Digging Force (Power Boost) ISO	25.300 (27.600) kgf
Arm Crowd Force (Power Boost) ISO	25.000 (27.300) kgf

